



2021 Curb, Gutter, and Sidewalk Bid Documents City of Devils Lake

The following items shall constitute a part of the bid documents:

1. Call for Bids Advertisement
2. 2021 Curb, Gutter and Sidewalk General Notes
3. NDDOT Standard Drawings D-748-1, D-750-1, D-750-2, and D-750-3
4. City Standard Drawing
5. 2021 Bid Sheet

CALL FOR BIDS

Sealed bids will be received by the Board of City Commissioners until 5:00 pm, April 5, 2021, for “2021 Curb, Gutter and Sidewalk”. Bids will be opened and publicly read at 5:30 pm, April 5, 2021.

Copies of the plans and specifications are available in the office of the City Engineer, City Offices, 423 6th St NE, PO Box 1048, Devils Lake, ND, 58301.

The Board of City Commissioners reserve the right to reject any or all bids, to waive technicalities, or to award each section of the project individually, or in any combination thereof, that is deemed in the best interest of the City.

Each bid must be labeled on the outside of the envelope with the following:

1. Name of the person/firm submitting bid.
2. Must be marked “2021 Curb, Gutter and Sidewalk Bid”.
3. Bidder must include a two percent (2%) bid bond or certified check, and copy of current contractor’s license with the proposal for consideration.

Dated at my office this 15th day of March, 2021.

Linda Lybeck
City Auditor

For legals: 3-19-21, 3-26-21, 4-1-21

2021 Curb, Gutter, Sidewalk and Driveway General Notes City of Devils Lake

100-P01 GENERAL: Complete construction according to the 2020 Standard Specifications adopted by the North Dakota Department of Transportation (NDDOT) and the Supplemental Specifications effective on the date the project is advertised. Amend the specifications as follows: the term “Department” will mean the City of Devils Lake or its authorized representative. The terms “Director” and “Engineer” will mean the City Engineer of Devils Lake or the City’s authorized representative.

100-P02 QUANTITIES: Quantities listed reflect an estimate for total work to be completed in the 2021 construction season and actual quantities may vary from those listed. An increase or decrease from plan quantity will not be accepted as a reason to negotiate any price adjustment. Contractor may provide a bid for any or all items listed.

100-P03 CONCRETE: Provide concrete meeting the specifications of Class AE concrete with a 28-day breaking strength of 4000 psi for concrete used for sidewalk and curb and gutter. Provide concrete meeting the specifications of High-Early Strength Class AE concrete with a 3-day breaking strength of 3500 psi for concrete used for valley gutter, driveways and roadway repair.

100-P04 WARRANTY: All work completed under this contract will be covered by a two-year warranty against defective materials or workmanship. Said warranty will also cover any settlement that may occur on the work completed. Repair or replacement of items of work found defective within the two-year timeframe will be done by the Contractor at the Contractor’s expense.

100-P05 COMPLETION: Begin work on an individual section of the project within 30 days of that section of work being provided to the Contractor. Install new concrete where any concrete was removed within 7 days of initial concrete removal. Complete all site work, including clean up and seeding, within 14 days of initial concrete removal.

100-P06 MATERIAL STORAGE: Minimize use of adjoining roadways for storage of materials. Properly mark any materials placed on the roadway according to the Manual on Traffic Control Devices (MUTCD). The City will remove any materials stored on the roadway or public right of way longer than 7 days at the Contractor’s expense.

106-P01 MATERIAL TESTING: Engineer may perform testing on concrete and other material during placement. Material not meeting specifications will be replaced at the Contractor’s expense. All testing will be paid for by the Engineer.

108-P01 LIQUIDATED DAMAGES: For each calendar day past the 30 days allowed to initiate construction on an assigned section of work, the Contractor will be assessed \$100 per day liquidated damages. In addition, for each calendar day past the 7

days allowed to replace concrete once it is removed, the Contractor will be assessed \$100 per day in liquidated damages. Additional days will be provided for inclement weather.

203-P01 EMBANKMENT: Compact embankment areas as directed by the Engineer in the field.

203-P02 EXCAVATION: Remove any sod, vegetation, or tree roots within the construction area and dispose in a location approved by the Engineer. Include all costs to remove and dispose of this material in the bid price for the appropriate bid item.

Complete all excavation in such a manner as to leave any utilities, finished lawns, adjacent sidewalks and boulevards in good condition and to protect any trees or shrubs adjacent to the work. Any damage caused by the Contractor to these items will be repaired at the Contractor's expense.

570-P01 FULL DEPTH CONCRETE STREET REPAIR: Includes all sawing, concrete removal and disposal, base preparation, drilling, doweling, concrete and placement, sealing and all other items required to complete full depth concrete pavement removal and replacement according to the attached drawing and NDDOT specifications. This bid item will be used for small sections (one panel or less in size) of concrete street repair within the downtown area. Concrete thickness is approximately 8 inches. Minimal base preparation will be required unless contractor disturbs base. Payment for all work to remove and replace concrete pavement as marked by Engineer in the field shall be included in this bid item. Payment will be based on the square yard of concrete pavement removed and replaced according to drawings and specifications.

704-P01 TRAFFIC CONTROL: Coordinate with the City to install traffic control devices when performing work in roadway area. The City will provide the traffic control devices for any work completed on the City's right of way.

748-P01 CURB AND GUTTER: When replacing curb and gutter without removing adjacent asphalt, use a 1/4" form board between road and curb. If the Engineer determines an adjacent asphalt section of roadway needs to be removed to replace curb, the Engineer will coordinate the amount and method for asphalt removal by the Contractor. Asphalt replacement will be completed by City forces at no expense to the Contractor.

748-P02 VALLEY GUTTER: Thoroughly compact all excavated areas to a depth slightly below subgrade. Place a minimum 4" layer of approved gravel base on the compacted surface to bring the grade to proper elevation. Dampen the grade prior to placement of concrete, as directed by the Engineer. Include the costs of the 4" gravel base in the unit bid price for valley gutter.

750-P01 REINFORCED CONCRETE: The City may request sidewalk or driveway concrete to be reinforced with rebar. Payment for any concrete that is requested to have

rebar installed will be under the appropriate sidewalk or driveway bid item. Include the following reinforcement when requested:

- 4" Reinforced Concrete - 3/8" bar at 18" spacing each direction
- 6" Reinforced Concrete – 1/2" bar at 18" spacing each direction.

750-P02 SIDEWALKS: All excavation necessary to construct the sidewalk to grade established by the Engineer in the field will be included in the Contractor's bid price for the appropriate sidewalk bid item

Thoroughly compact all excavated and embankment areas to a depth slightly below subgrade and place a minimum 2" layer of approved granular material on the compacted surface to bring the grade to proper elevation. Thoroughly and uniformly compact the granular base and dampen prior to placement of concrete as directed by the Engineer. Include the costs of the 2" granular base in the unit bid price for the appropriate sidewalk bid item.

Provide 6" concrete sidewalk when crossing driveways. Include all costs to increase the thickness across the driveways in the appropriate 6" sidewalk/driveway bid item. In areas where the sidewalk is being replaced, use approved granular material to bring the sidewalk to proper elevation and establish a smooth, compact surface to place concrete. Compact and dampen granular base prior to placement of concrete. Include the costs of the granular base in the unit bid price for the appropriate sidewalk bid item.

The sidewalk elevation will be set by the Engineer in the field. Typical sidewalk elevation is shown on the attached drawing.

Use the attached expansion joint detail for all expansion joints located within new concrete areas.

Provide temporary signing and/or a supervisor along the fresh concrete sidewalk to prevent pedestrian use or other markings until such time that the sidewalk has cured to support such traffic. Include costs of signing and/or supervisor in the price bid for the appropriate sidewalk bid item. Replace any markings that occur during curing time and are not fixed before cured, at the Contractor's expense.

Complete sawing of the existing sidewalk at both ends of the sidewalk to be replaced. This work will be paid at the unit price bid for "SAWING CONCRETE."

Minor grading, topsoil and seeding required to blend the sidewalk to the existing grade will be incidental to the appropriate sidewalk bid item.

Any additional topsoil and seeding required beyond the sidewalk replacement area will be paid under the bid item "TOPSOIL AND SEEDING."

Coordinate removal of large stumps and roots required for installation of sidewalk, once approved by the Engineer. Include approved stump removal cost on an invoice, to be billed to the City, separate from the Curb, Gutter & Sidewalk pay estimate.

750-P03 DRIVEWAYS: Include all excavation necessary to construct the driveway to the grade established by the Engineer in the unit bid price for the appropriate driveway bid item.

Thoroughly compact all excavated areas to a depth slightly below subgrade and place a minimum 4" layer of approved gravel base on the compacted surface to bring the grade to the proper elevation. Thoroughly and uniformly compact the gravel base and dampen prior to placement of concrete as directed by the Engineer. Include the costs of the 4" gravel base in the unit bid price for the appropriate driveway bid item.

Provide temporary signing and/or a supervisor along the fresh concrete driveway to prevent use or other markings until such time that the sidewalk has cured to support such traffic. Include costs of signing and/or supervisor in the price bid for the appropriate driveway bid item. Replace any markings that occur during curing time and are not fixed before cured, at the Contractor's expense.

Minor grading, topsoil and seeding required to blend the driveway to the existing grade will be incidental to the appropriate driveway bid item.

Any additional topsoil and seeding required beyond the driveway replacement area will be paid under the bid item "TOPSOIL AND SEEDING."

Use Type 1 Driveways unless otherwise specified.

750-P04 RETAINING WALL REMOVAL: Retaining walls located adjacent to sidewalk areas may be required to be removed. This bid item will cover the cost for removing and disposing of the retaining wall. Payment will be made by the lineal foot of retaining wall removed, regardless of height.

750-P05 DETECTABLE WARNING PANELS: Provide Detectable Warning Panels that meet the requirements of Section 885.01 E.1 "Cast Iron".

Detectable Warning Panels will be installed in accordance with Standard Drawing D-750-3 and the manufacturer's recommendations. Coordinate all installations with the City to ensure proper placement. Include all costs to furnish and install the Detectable Warning panels in the price bid for "DETECTABLE WARNING PANEL".

2021 Curb, Gutter, Sidewalk and Driveway Bid Sheet

City of Devils Lake

<u>Item Description</u>	<u>Quantity</u>	<u>Unit Price</u>	<u>Extended Price</u>
Saw Bituminous Surfacing	50.00	LF _____	_____
Saw Concrete	100.00	LF _____	_____
Removal of Concrete	425.00	SY _____	_____
Removal of Block Sidewalk	20.00	SY _____	_____
Removal of Curb & Gutter	150.00	LF _____	_____
Removal of Retaining Wall	10.00	LF _____	_____
Curb & Gutter - Type I	20.00	LF _____	_____
Over 10'	100.00	LF _____	_____
Valley Gutter - 8" Reinforced	5.00	SY _____	_____
Over 3 SY	40.00	SY _____	_____
4" Sidewalk Concrete	300.00	SY _____	_____
4" Sidewalk Concrete – Reinforced	5.00	SY _____	_____
6" Sidewalk/Driveway Concrete	75.00	SY _____	_____
6" Sidewalk/Driveway Concrete – Rein.	5.00	SY _____	_____
8" Concrete	10.00	SY _____	_____
8" Concrete - Reinforced	5.00	SY _____	_____
Detectable Warning Panel (Cast Iron)	32.00	SF _____	_____
Earthen Excavation	10.00	CY _____	_____
Earthen Embankment	10.00	CY _____	_____
Gravel Base	10.00	CY _____	_____
Topsoil and Seeding	25.00	SY _____	_____
Concrete Full Depth Street Repair	30.00	SY _____	_____
 Total Bid			 \$ _____

The undersigned agrees to furnish all materials and perform all labor required to complete this project according to the plans and specifications.

Name of person/firm submitting bid (please print) _____

Authorized signature _____ Date _____

Address _____ Phone _____

Curb & Gutter and Valley Gutter

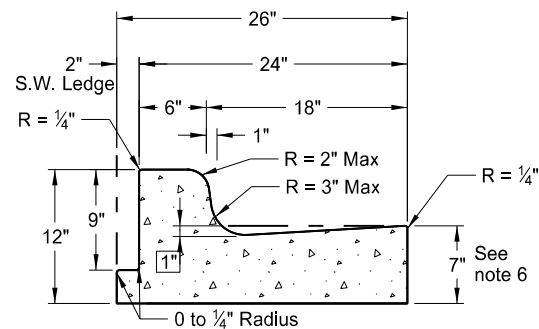

Curb & Gutter Type 1 (Sec. A & B)
Adjacent to Concrete Sidewalk,
Median, or Parking Lot.
(Sec. A shown. See Sec B for
additional details.)

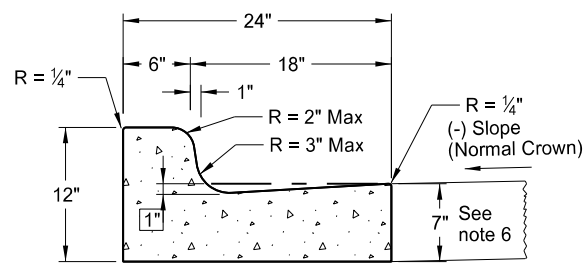

Curb & Gutter Type 1 (Sec. A)

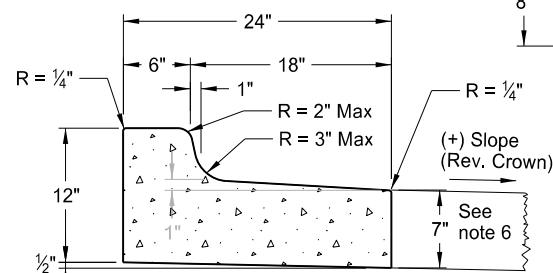

Curb & Gutter Type 1 (Sec. B)

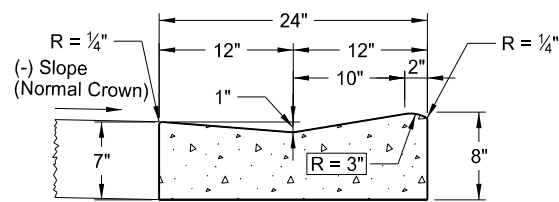

Mountable Curb & Gutter Type 1 (Sec. A)

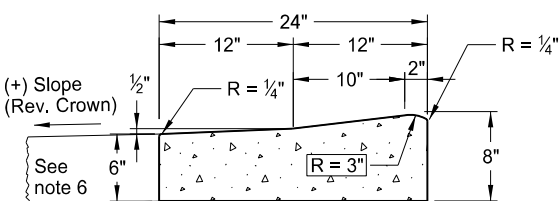

Mountable Curb & Gutter Type 1 (Sec. B)

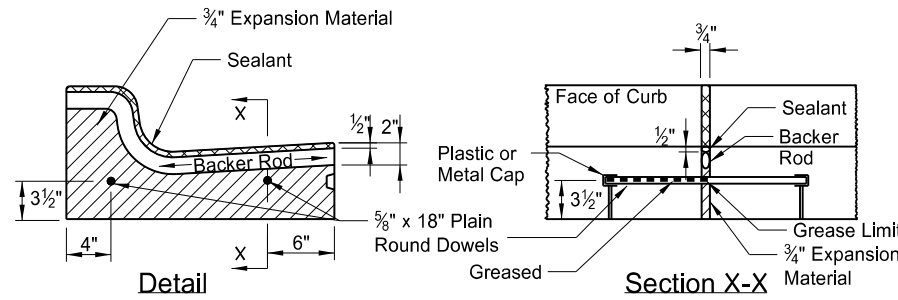

Isolation Joint

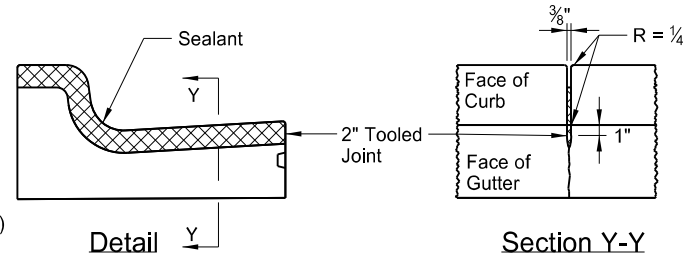

Contraction Joint

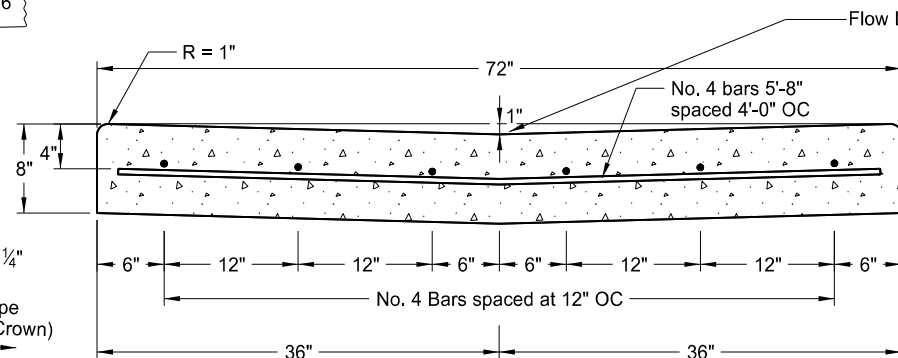

72" Concrete Valley Gutter Detail

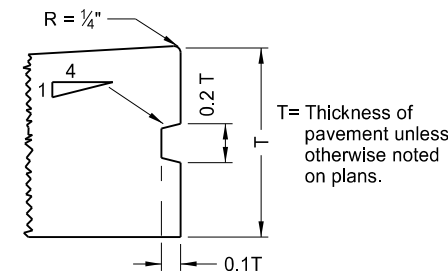

Keyway Detail for Curb & Gutter
(To be used with PCC Pavement and Drives)

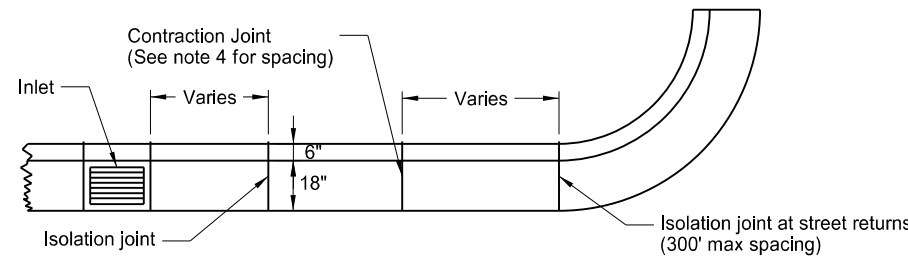

Joint Location Detail

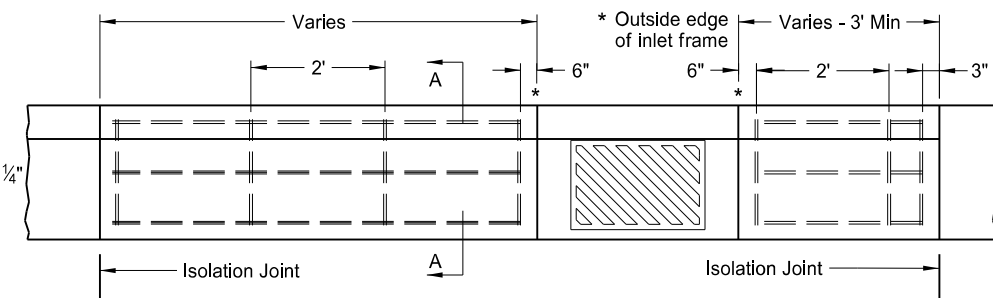

Curb & Gutter Reinforcing at Inlets

NOTE: Use #4 deformed reinforcing bars without splices. Include all costs for reinforcing bars at inlet locations (even inlets located on radii) in the price bid for "Curb and Gutter - Type 1." Extend reinforcement to the second joint (rebar placed through the first joint) in cases where the 3' min. panel length cannot be obtained.

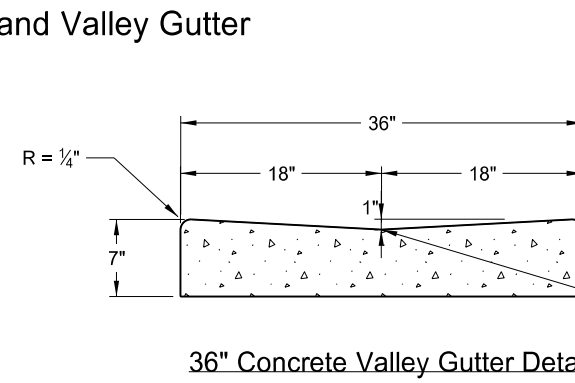

36" Concrete Valley Gutter Detail

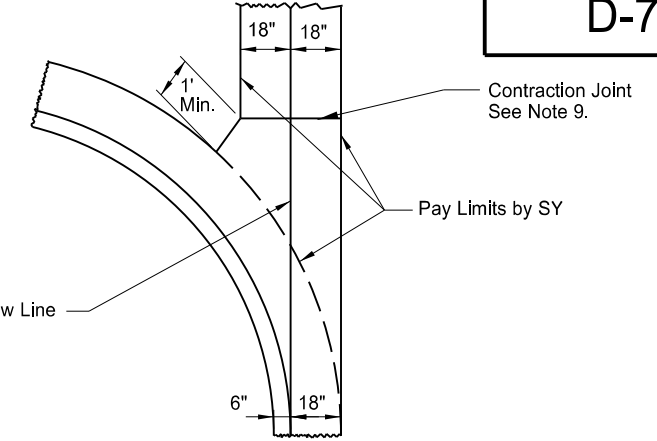

36" Concrete Valley Gutter Plan

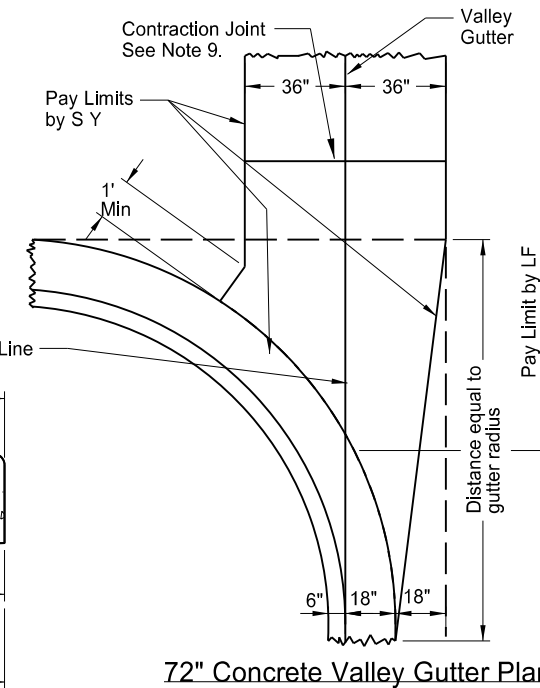

72" Concrete Valley Gutter Plan

NOTES:

1. Use Curb and Gutter Type 1 (Sec. A & B). Use section "A" with (-) pavement slopes and section "B" with (+) pavement slopes.
2. Contraction Joints: Tool the Curb & Gutter 2" as shown on the contraction joint details.
3. Isolation Joints: Use 3/4" expansion joint filler for isolation joint material. Form the backer rod and joint sealant opening with a pre-cut piece of wood or other material approved by the engineer. Dowel supports are not required on the second pour at a cold joint. Install plastic or metal caps and greased dowels in the cold joint for the second pour.
4. Joint Spacing: For hot bituminous pavements use a 10' max joint spacing for the curb and gutter with panels on each side of the inlets. For concrete pavements match the joint spacing for the curb and gutter to the pavement joint on PCC Pavements (approximately 15' spacing.)
5. Joint sealing: Seal contraction and isolation joints as shown in the details. Use joint sealant for contraction joints that conforms to section 826.02B. Use sealant for expansion joints specified in note 3 above. Tool and install sealant in accordance with the manufacturer's recommendations.
6. Face of Gutter Depth: For hot bituminous pavement use 7" gutter depth as shown. For PCC pavements, match the gutter depth to the depth of adjacent PCC pavement or to construct a 7" depth as shown.
7. Tie curb and gutter to abutting PCC pavement with No. 3 bars, 1'-6" in length, spaced at 4' centers.
8. On street returns and other locations where new curb and gutter ends and does not abut existing curb and gutter, taper the last two (2) feet of the curb from 6" in height to 0". Install a 1/2" premolded full depth isolation joint, the same shape as the curb and gutter just ahead of the taper. Install an 18" tie bar across the joint.
9. Valley Gutter Joints: Form, saw, or score 1/8" min. to 3/8" max. width contraction joints (a minimum 2" depth) at approx 10' intervals. Seal the joints with hot poured elastic type joint sealer (Section 826.02A.2 of the Standard Specifications.) Include all costs for the joint and sealant in the price bid for Valley Gutter.

NORTH DAKOTA DEPARTMENT OF TRANSPORTATION	
8-7-2013	
REVISIONS	
DATE	CHANGE
10-17-17	Updated to active voice.
08-27-19	New Design Engr PE Stamp.

This document was originally issued and sealed by
Kirk J Hoff,
Registration Number
PE-4683,
on 8-27-19 and the original document is stored at the North Dakota Department of Transportation

CONCRETE DRIVEWAY - URBAN

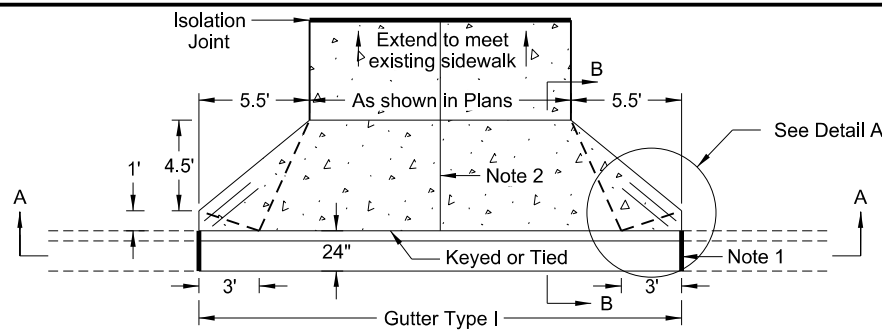

Driveway Type 1

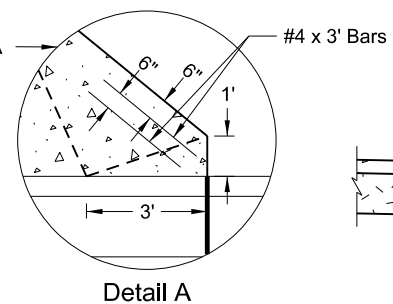

Detail A

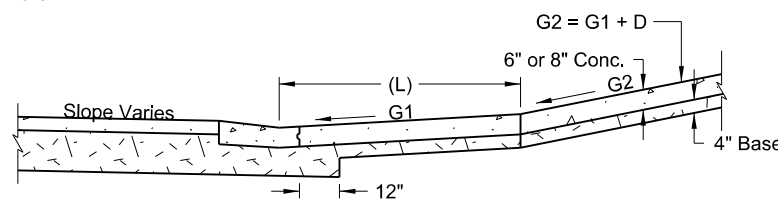

Sag - Driveway Type 1

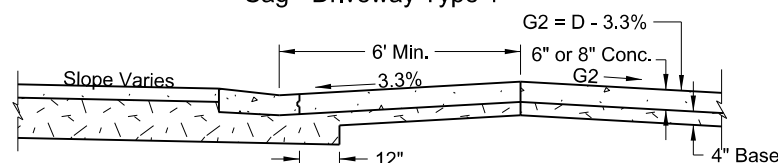

Summit - Driveway Type 1

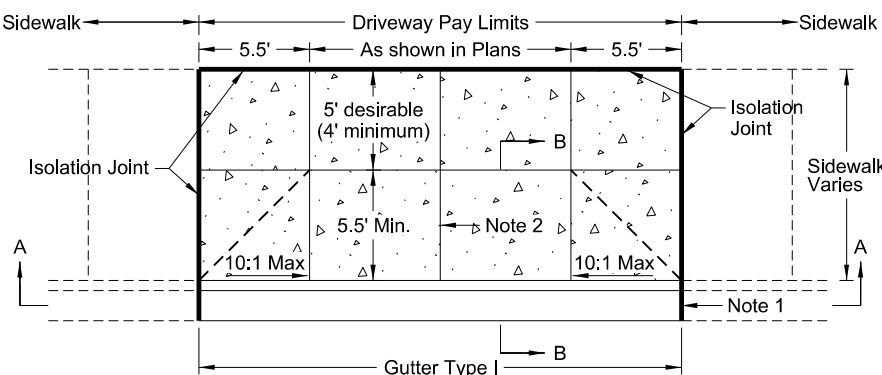

Driveway Type 2A

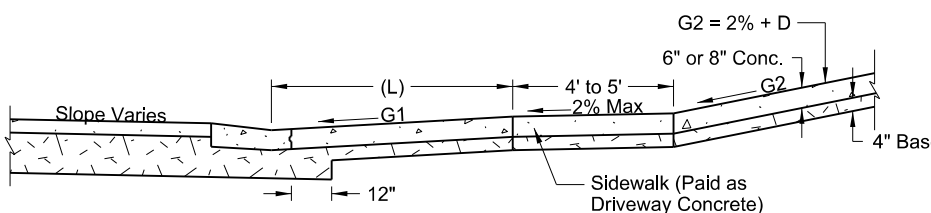

Sag - Driveway Types 2A & 2B

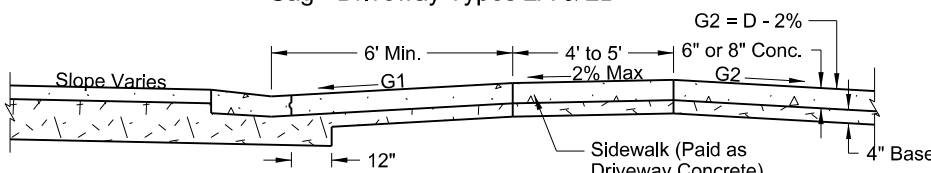

Summit - Driveway Types 2A & 2B

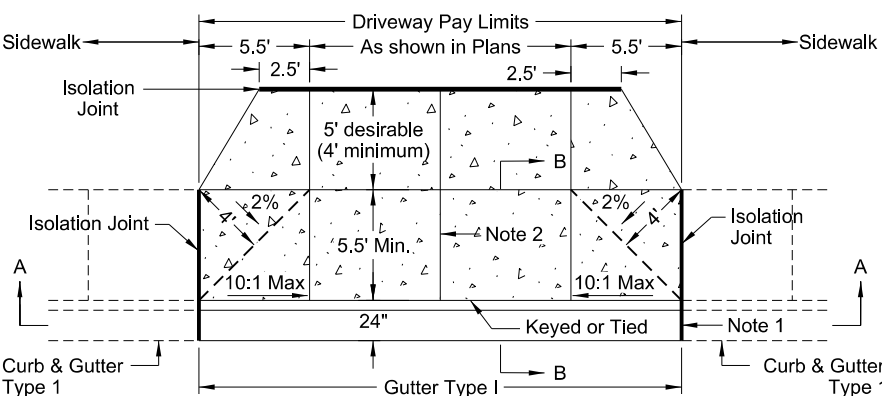

Driveway Type 2B

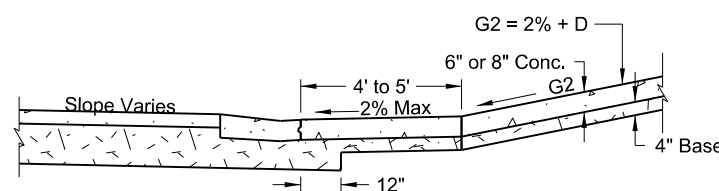

Sag - Driveway Type 3

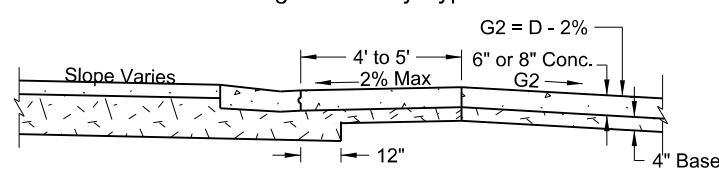

Summit - Driveway Type 3

- NOTES:
- See Standard D-748-1 for curb and gutter isolation joint detail. On PCC roadways, match curb and gutter joints with pavement joints, as much as practical.
 - Joint Spacing: Use 1 center contraction joint on driveways 20' width or less, 2 center contraction joints for driveways 20' to 30' width, and 3 center contraction joints for driveways greater than 30' width.
Saw or groove contraction joints a minimum depth of 1/3 the depth of the concrete.
Use isolation joints between separately poured concretes, or between old and new concrete.
Seal joints with hot pour bituminous filler or low modulus silicone. Install and tool sealant according to manufacturer's recommendations.
Include all costs for labor, equipment, and material to construct and seal joints in the price bid for the driveway.
 - Include all costs for gutter-Type 1 in the unit price bid for "Curb and Gutter-Type 1".
 - Use 6" driveway unless otherwise specified.
 - Place 4" base material under concrete driveway. Include all costs for labor and materials necessary to place the base material in the price bid for Salvage Base Course or Aggregate Base Course CL 5.
 - Construct sidewalk behind a driveway to the same thickness as the driveway. The Engineer will measure it as driveway concrete.



Section A-A

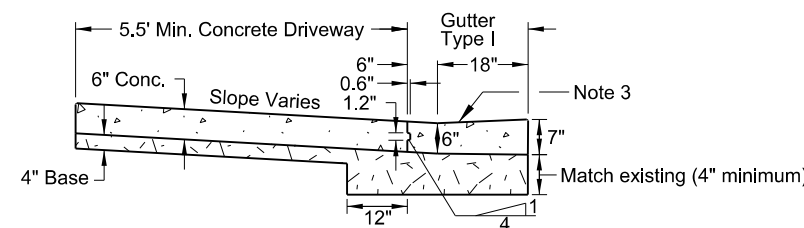

6" Section B-B

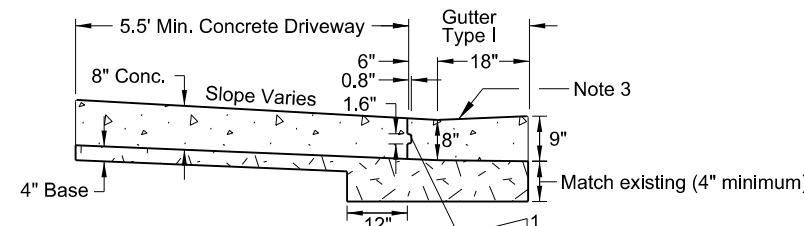

8" Section B-B

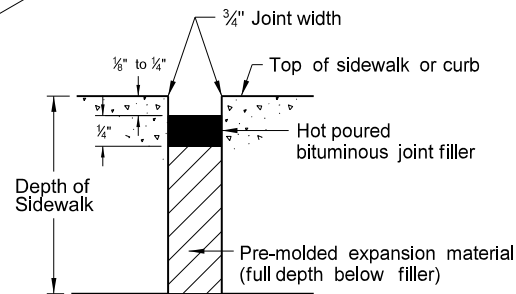

Typical Isolation Joint Seal (longitudinal and transverse)

Driveway ADT	Grade G1		Dimension (L) ft.		Grade Changes (D)	
	Desirable	Maximum	Desirable	Maximum	Desirable	Maximum
(0-500)	5%	12% or controlled by vehicle clearance	12	6	6%	15% or controlled by vehicle clearance
(500-1500)	3%	8%	20	20	3%	6%
(> 1500)	2%	5%	40	40	0%	3%

NORTH DAKOTA DEPARTMENT OF TRANSPORTATION	
2-13-2014	
REVISIONS	
DATE	CHANGE
10-17-17 08-27-19	Updated to active voice. New Design Engineer PE Stamp.

This document was originally issued and sealed by
Kirk J Hoff,
Registration Number
PE-4683,
on 08/27/19 and the original document is stored at the North Dakota Department of Transportation

SIDEWALK

NOTES:

1. Curb ramp and detectable warning panel layouts for informational purposes only. See Standard Drawing D-750-3 for curb ramp and detectable warning panel details.
2. Joint Spacing: Vary transverse contraction joint spacing from 4' to 6' to create approximate square panels.
Use longitudinal contraction joints when sidewalk width is 8' or greater, and space at half the sidewalk width.
Saw or groove contraction joints to a minimum depth of 1/3 the depth of the concrete.
When sidewalk is adjacent to curb & gutter, vary the sidewalk joint spacing to match curb & gutter joints.
Use isolation joints between separate concrete pours, or between old and new concrete.
3. Include all costs for labor, equipment, and material necessary to construct contraction and isolation joints in the price bid for sidewalk concrete.
4. Use 4" sidewalk concrete thickness unless otherwise specified.
5. Use 4" base material thickness unless otherwise specified. Include all costs for labor and materials necessary to place the base material in the price bid for "Salvage Base Course" or "Aggregate Base Course CL 5."
Modify existing ground slope with landscaping as needed. If not possible, such as adjacent buildings, use a vertical curb as shown in the detail below. The Engineer will measure curb at the unit price bid for "Curb - Type I" per lineal foot.
6. Sidewalk Width & Grade: Provide a continuous 4' min clear width pedestrian access route with max 2% concrete cross slope, excluding flares. The width of the curb cannot be counted as part of the pedestrian access route.
When clear width of pedestrian access routes is less than 5.0', provide passing spaces at a maximum of 200' with a minimum size of 5.0' by 5.0'.

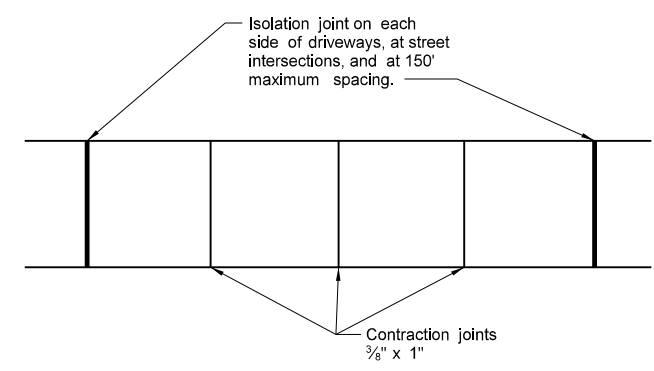
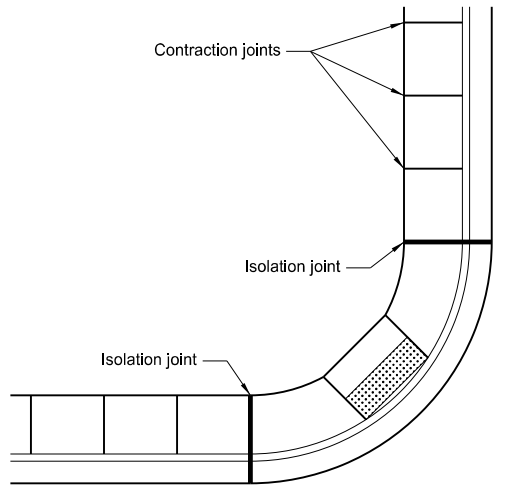
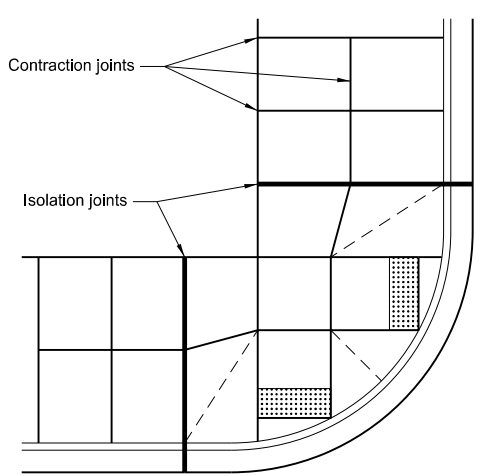
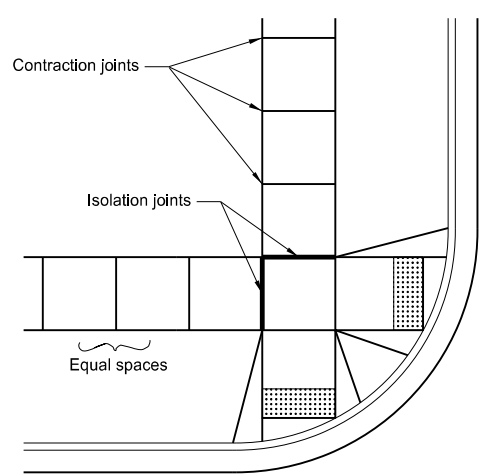

Typical Joint Layouts

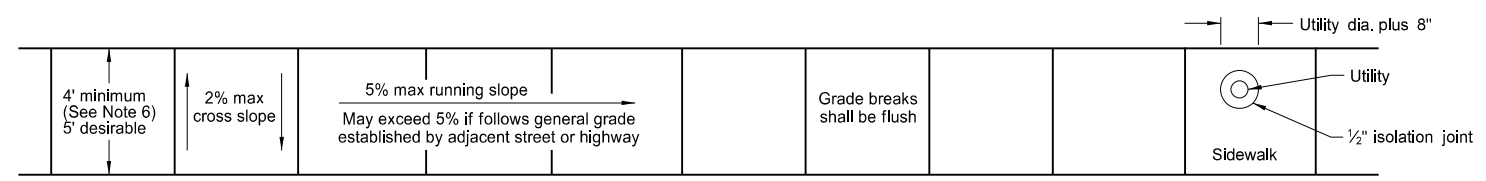

Sidewalk Width and Grade

Utility Blockout

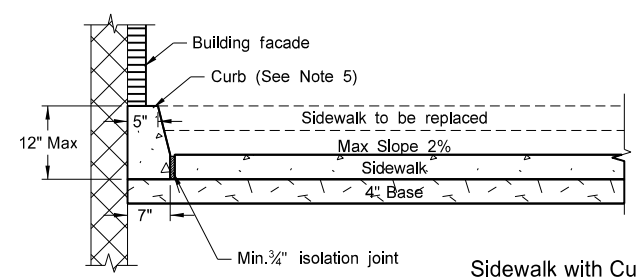

Sidewalk with Curb Detail (Building face application)

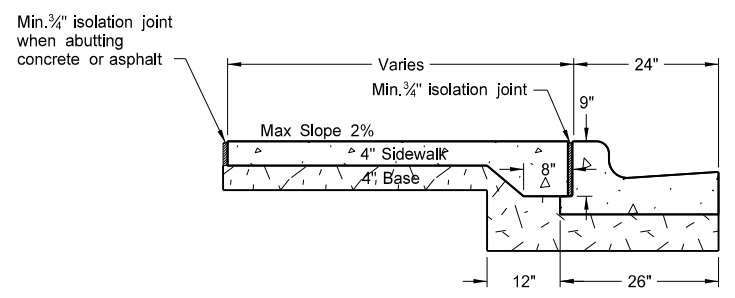

Sidewalk Detail (Installed adjacent to curb and gutter)

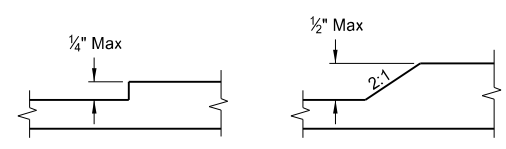

Vertical Discontinuities (As needed for utility covers, vaults, grating, etc..)

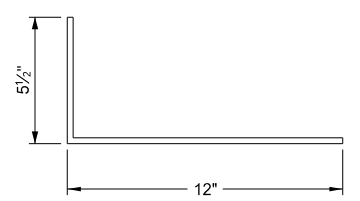

"L" Bar Detail #3 Bar

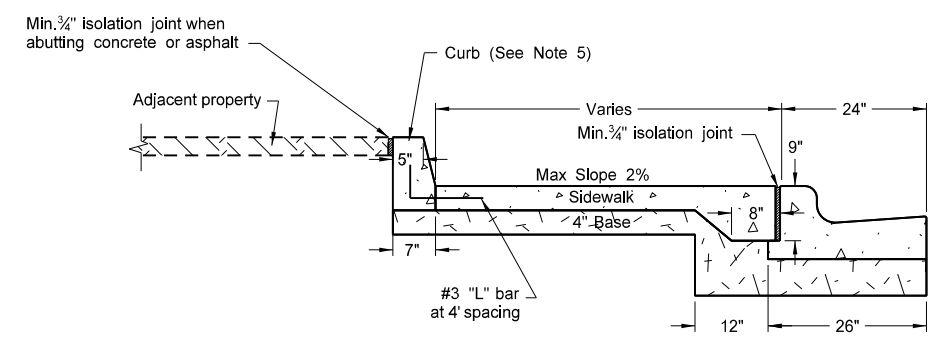

Sidewalk with Curb Detail (Adjacent property application)

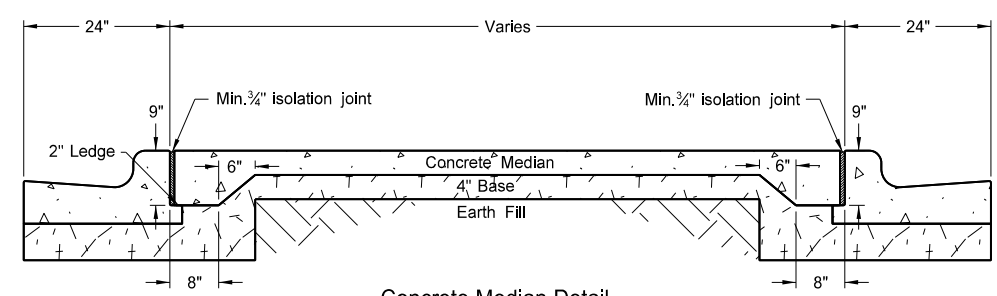

Concrete Median Detail

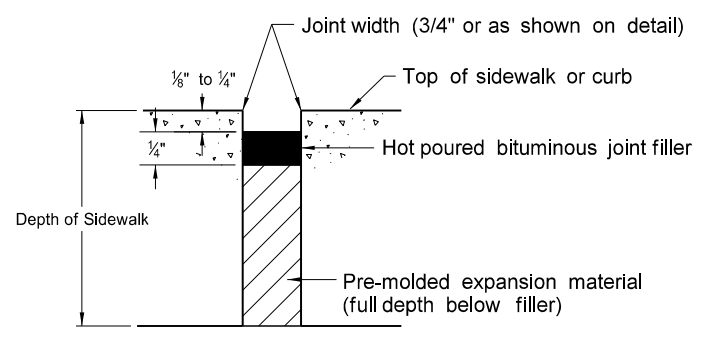

Typical Isolation Joint Seal (longitudinal and transverse)

NORTH DAKOTA DEPARTMENT OF TRANSPORTATION	
11-26-13	
REVISIONS	
DATE	CHANGE
10-17-17	Updated to active voice.
09-05-18	Added sidewalk details for width and grade and passing lane requirements.
08-27-19	New Design Engineer PE Stamp.

This document was originally issued and sealed by
Kirk J Hoff,
Registration Number
PE-4683,
on 08/27/19 and the original document is stored at the North Dakota Department of Transportation

CURB RAMP DETAILS

D-750-3

NOTES:

- Ramp width is the useable portion of the ramp, excluding flares. Match curb ramp width to existing sidewalk width (4' minimum or 5' for island ramps.) Match ramp width to existing shared use path width. Maximum ramp length is 15'.
- Desirable turning space size is 5' x 5' or larger with a minimum size of 4' x 4'. The maximum slope for turning spaces is 2% in any direction.
- Match detectable warning panel width to ramp width. Radial panels are allowed. Place detectable warning panel within the lower turning space.
- Provide a continuous 4' minimum width pedestrian access route with max 2% concrete cross slope, excluding flares.
- Modify existing ground slope with landscaping, as needed. If not possible, such as adjacent buildings, use a vertical curb as shown in the detail below. The Engineer will measure curb at the unit price bid for "Curb - Type 1" per lineal foot.
- Islands: If the grade of the island curb ramp is less than 2%, provide a minimum distance of 2' between warning panels. If the grade of the island curb ramp is steeper than 2%, provide a turning space between the ramps.

+More Right of Way ← | → Right of Way -

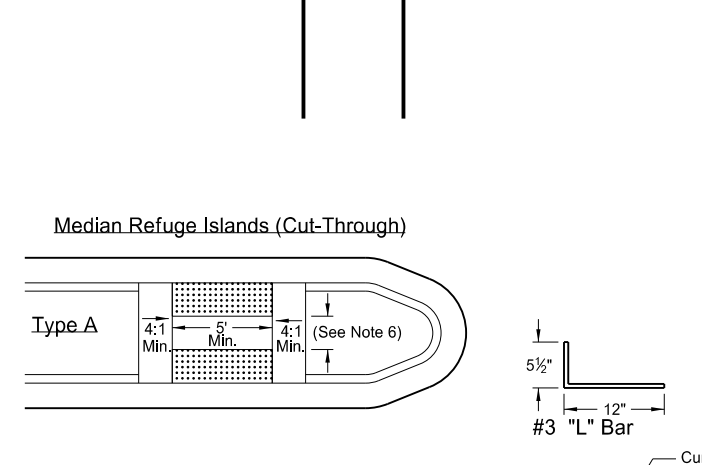
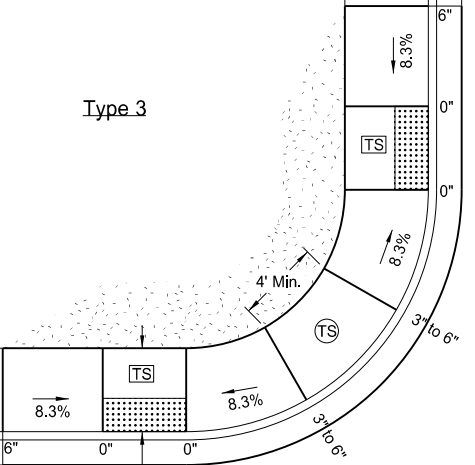
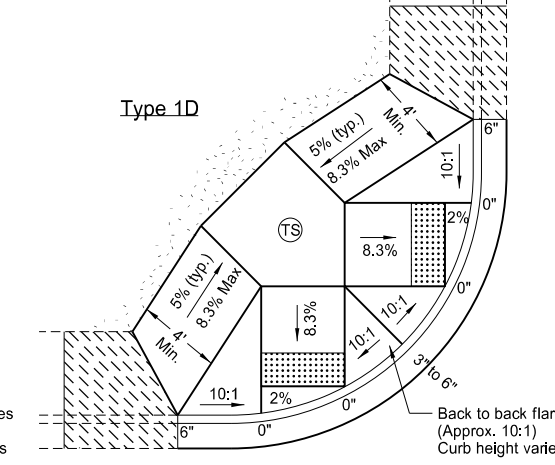
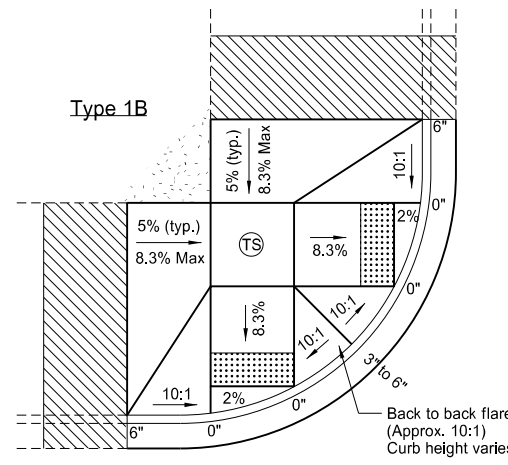
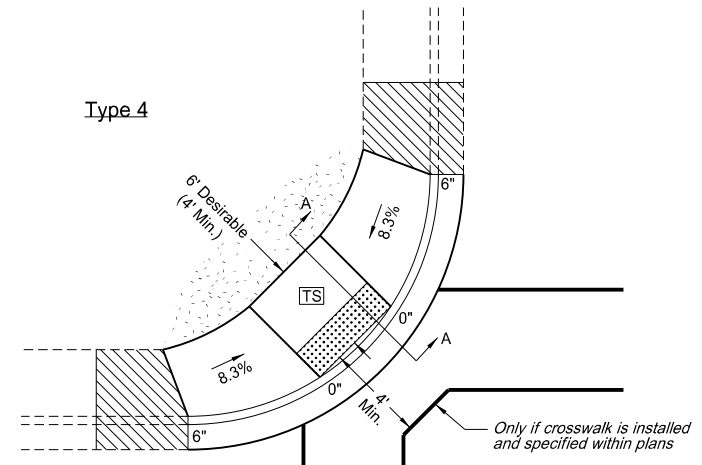
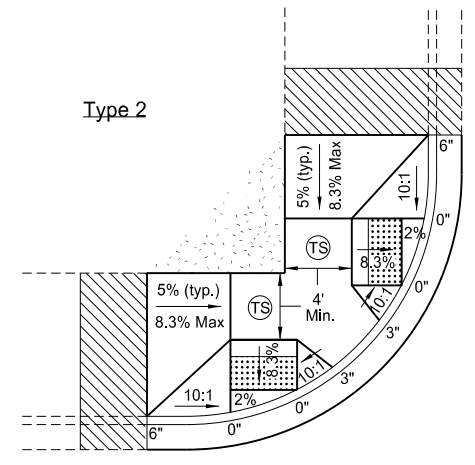
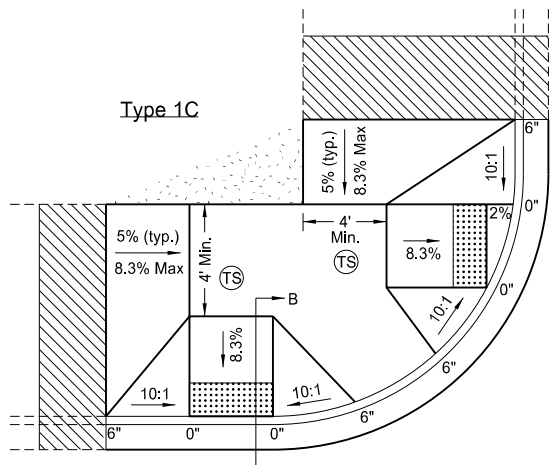
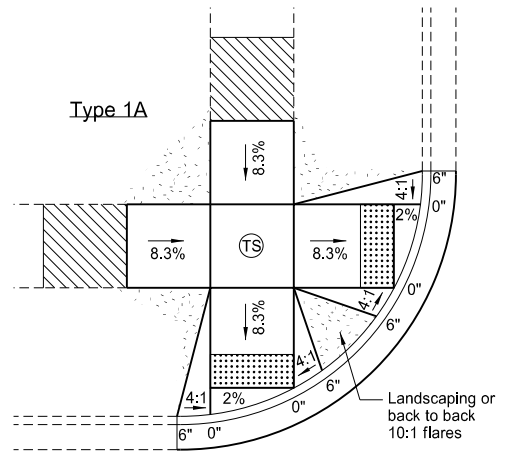

LEGEND:

- : Detectable Warning Panel
- : Landscaping
- : Transitional tie-in segment if needed for retrofits. Max grade slope 8.3%.
- : Upper Turning Space
- : Lower Turning Space
- 0", 3", or 6" : Curb Height
- 8.3% : All slopes shown are max grades. Flatter slopes may be used.

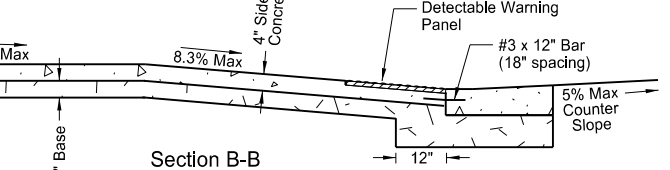
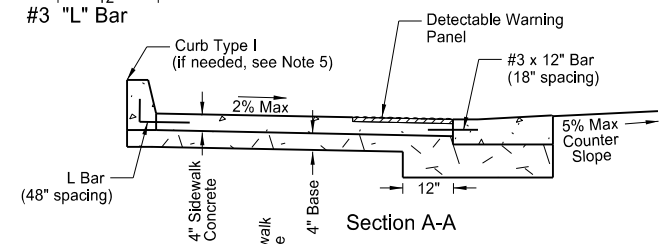
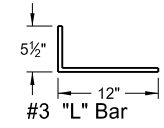
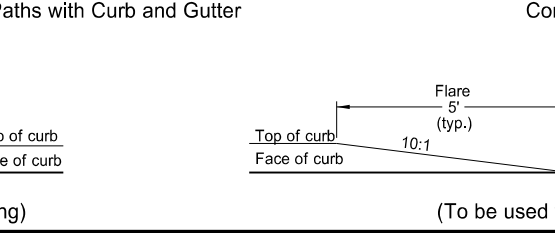
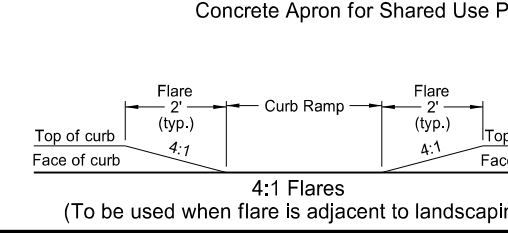
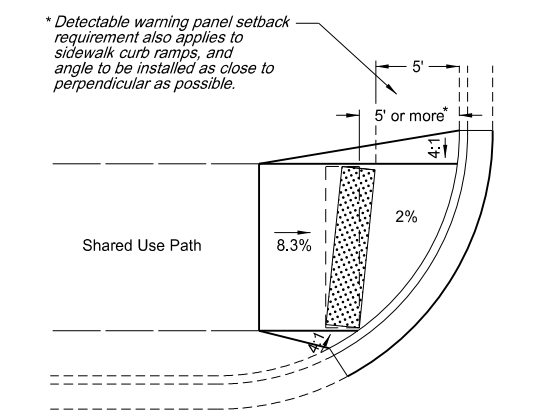
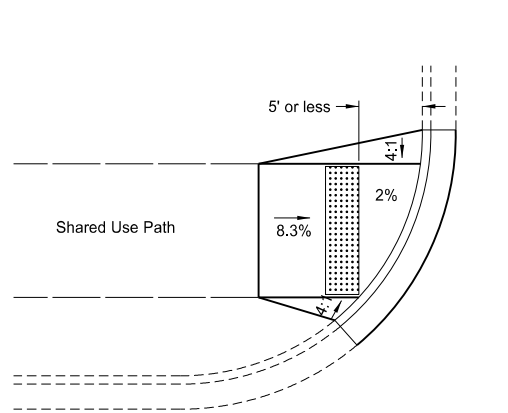

NORTH DAKOTA DEPARTMENT OF TRANSPORTATION	
11-26-13	
REVISIONS	
DATE	CHANGE
10-17-17	Updated to active voice.
09-05-18	Revised Notes, Revision for Turning Space, Added Passing Space Requirements, Turned Detectable Warning Panel

This document was originally issued and sealed by Roger Weigel, Registration Number PE-2930, on 09-05-2018 and the original document is stored at the North Dakota Department of Transportation

STATE	PROJECT NO.	SECTION NO.	SHEET NO.
ND	-	-	-

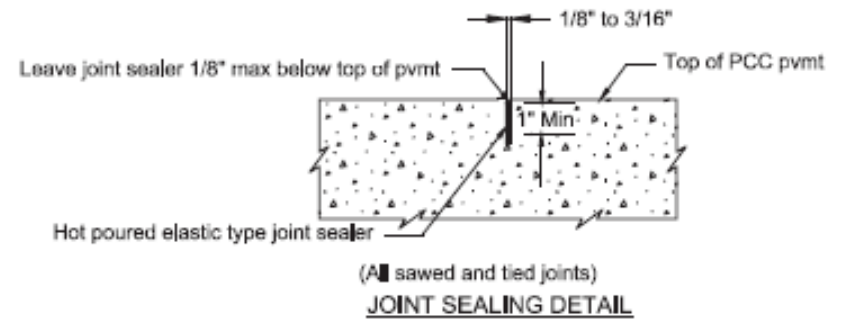
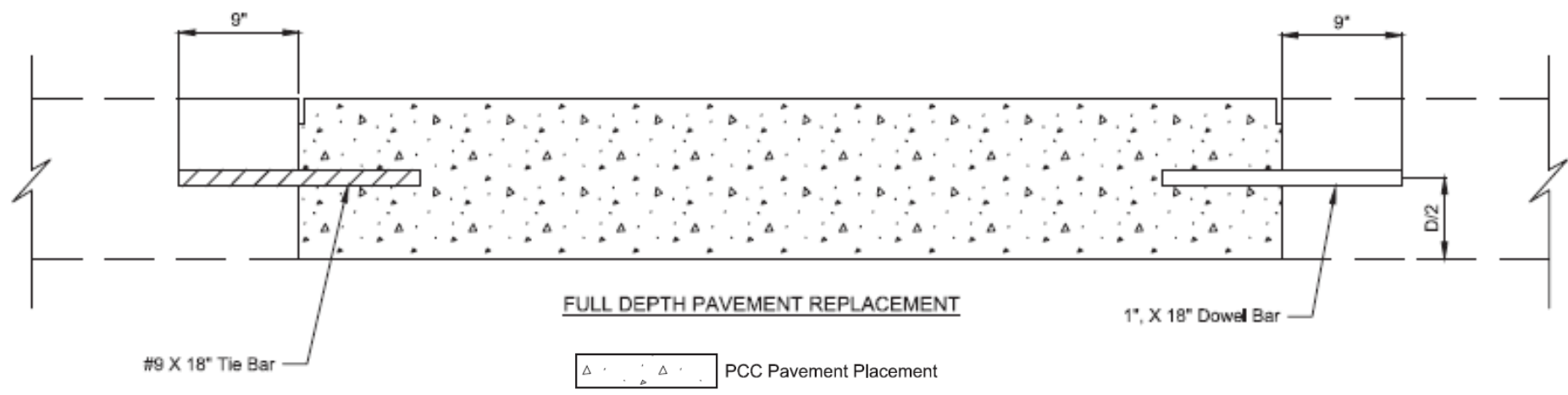
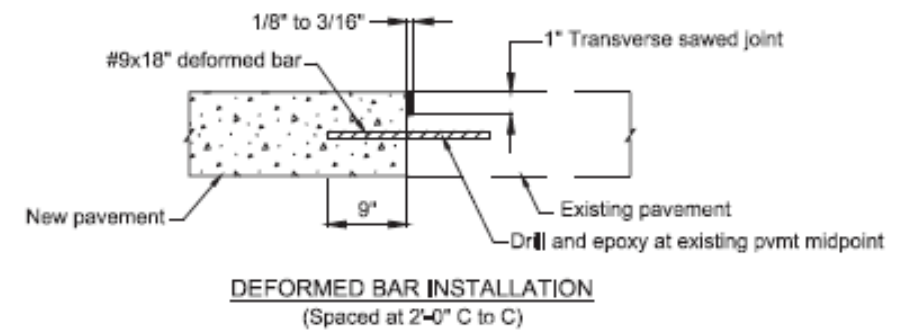
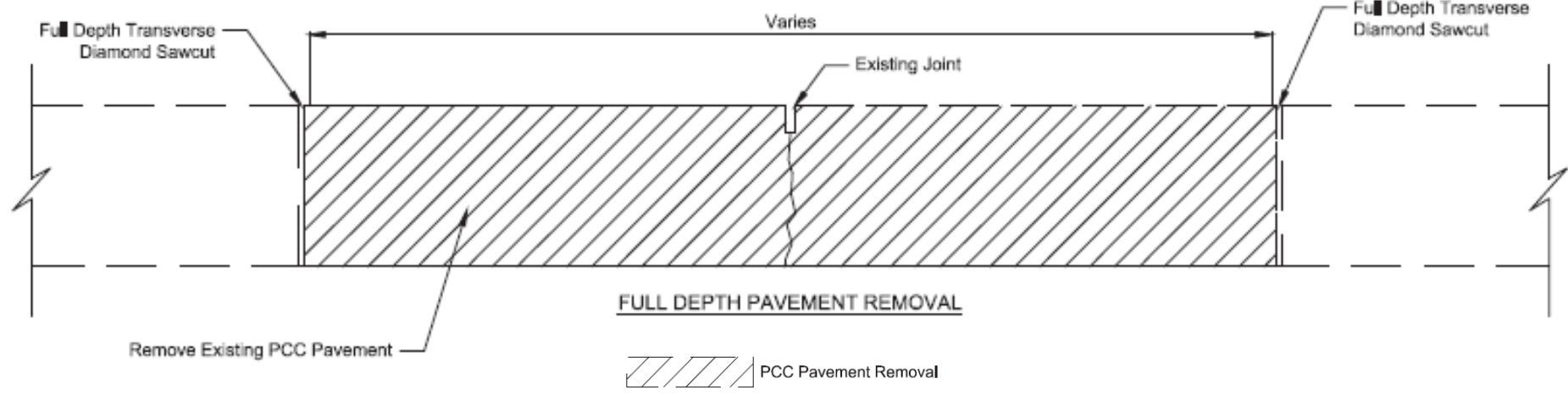

- Notes:
1. Variables: D = Depth of Pavement
 2. Use smooth dowel bar in place of deformed tie bar when replacing full length of panel.

This document is a reference and is intended for informational purposes only.



**STANDARD DETAIL
FULL DEPTH
PAVEMENT REPAIR**

DRAWN BY	DATE	PROJECT NO.
DTG	MG	-